

DESCHUTES COUNTY ROAD DEPARTMENT WILCOX AVE BRIDGE REMOVAL

JANUARY 2025

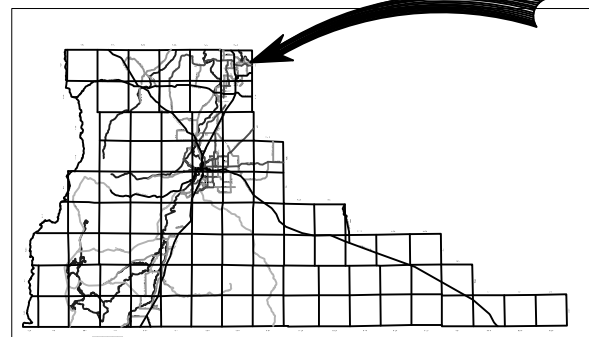

VICINITY MAP

SHEET INDEX

SHEET 2	WILCOX AVE PLAN AND PROFILE
SHEET 3	CULVERT PLAN AND PROFILE
SHEET 4	FLUME PLAN AND PROFILE
SHEET 5	TRENCH DETAILS
SHEET 6	HEADWALL DETAILS

OREGON STANDARD DRAWING INDEX

RD300	TRENCH BACKFILL, BEDDING, PIPE ZONE AND MULTIPLE INSTALLATIONS
RD339	PIPE TO STRUCTURE CONNECTIONS
RD403	MIDWEST GUARDRAIL SYSTEM WOOD POST AND BLOCK
RD406	PLACEMENT OF GUARDRAILS ON SLOPES
RD610	ACP DETAILS
RD1030	SEDIMENT BARRIER, TYPE 2, 3 AND 4
TM800	TABLE, ABRUPT EDGE AND PCMS DETAILS
TM840	CLOSURE DETAILS

BASIS OF BEARINGS

BASED ON CENTRAL OREGON COORDINATE SYSTEM (COCS) DESCHUTES 13 TRANSFORMATION, DERIVED FROM THE OREGON-REAL-TIME GNSS NETWORK (ORGN)

DATUM

HORIZONTAL: COORDINATES ARE INTERNATIONAL FEET, BASED ON COCS
VERTICAL: ELEVATIONS ARE NVGD29, BASED ON COCS



AREA MAP

OWNER

DESCHUTES COUNTY
CONTACT: CODY SMITH, PE
61150 SE 27TH ST
BEND, OR 97702
(541) 322-7113

GENERAL NOTES

- ALL WORK SHALL BE PERFORMED IN ACCORDANCE WITH THE CONTRACT SPECIAL PROVISIONS AND THE 2024 OREGON STANDARD SPECIFICATIONS FOR CONSTRUCTION.
- A TOPOGRAPHICAL SURVEY WAS PERFORMED BY DESCHUTES COUNTY. FIELD SURVEYS REFERENCE THE VERTICAL AND HORIZONTAL DATUMS LISTED IN THE PLANS, SURVEYS OF RECORD, AND INFORMATION OBTAINED FROM UTILITY COMPANIES.
- CONTRACTOR SHALL VERIFY ALL EXISTING CONDITIONS AT PROJECT SITE BEFORE START OF WORK. IF THE CONTRACTOR DISCOVERS DIFFERING SIT CONDITIONS, THE CONTRACTOR SHALL PROMPTLY NOTIFY THE AGENCY, IN WRITING, OF THE SPECIFIC DIFFERING CONDITIONS BEFORE THEY ARE DISTURBED AND BEFORE THE AFFECTED WORK IS PERFORMED. CONTRACTOR SHALL NOT CONTINUE WORK IN THE AFFECTED AREA UNTIL THE AGENCY HAS INSPECTED SUCH CONDITION ACCORDING TO OSSC 00195.30 TO DETERMINE WHETHER AN ADJUSTMENT TO CONTRACT AMOUNT OR CONTRACT TIME IS REQUIRED.
- CONTRACTOR SHALL FOLLOW APPLICABLE RULES ADOPTED BY THE OREGON UTILITY NOTIFICATION CENTER. THE OREGON UTILITY NOTIFICATION CENTER CAN BE REACHED BY DIALING 811, OR ONLINE AT WWW.CALLBEFOREYOU.DIG.ORG/OREGON. CONTRACTOR SHALL ALSO COMPLY WITH ALL PROVISIONS OF SECTION 00150.50 OF THE OSSC AND SPECIAL PROVISIONS.
- ALL UTILITIES SHOWN ARE COMPILED FROM AVAILABLE RECORDS AND/OR FIELD SURVEYS. THE AGENCY DOES NOT GUARANTEE THE ACCURACY NOR THE COMPLETENESS OF SUCH RECORDS. CONTRACTOR SHALL DETERMINE THE EXACT LOCATION BEFORE EXCAVATING WITHIN THE TOLERANCE ZONE ACCORDING TO OAR 952-001-0090(3)(c).
- CONTRACTOR SHALL RESTRICT ALL OPERATIONS TO THE PROJECT LIMITS. CONTRACTOR SHALL NOT ENTER ONTO PRIVATE PROPERTY WITH EQUIPMENT OR MATERIAL UNLESS WRITTEN PERMISSION IS OBTAINED FROM A PROPERTY OWNER. ANY DISRUPTION TO PRIVATE PROPERTY AND/OR LANDSCAPING OUTSIDE THE PROJECT LIMITS INDICATED ON THE PLANS SHALL BE RESTORED AT CONTRACTOR'S EXPENSE.
- IN THE EVENT OF REMOVAL, DISTURBANCE OR DESTRUCTION OF A SURVEY MONUMENT OF RECORD, IT IS THE CONTRACTOR'S RESPONSIBILITY TO RE-ESTABLISH THE MONUMENT ACCORDING TO OSSC 00170.82. THE CONTRACTOR SHALL NOTIFY THE COUNTY SURVEYOR OF MONUMENT DISTURBANCE TO COORDINATE NECESSARY RESTORATION REQUIREMENTS.
- THE CONTRACTOR IS RESPONSIBLE FOR SITE SAFETY ACCORDING TO OSSC 00170.60. DESCHUTES COUNTY AND THEIR REPRESENTATIVES AND OFFICIALS SHALL NOT BE RESPONSIBLE FOR ENFORCING SAFETY REGULATIONS.
- CONTRACTOR IS REQUIRED TO PROVIDE AND MAINTAIN ACCESS FOR EMERGENCY VEHICLES AT ALL TIMES THROUGHOUT THE DURATION OF THE PROJECT. THIS INCLUDES PROVIDING A CLEAR AND UNOBSTRUCTED ROUTE FOR EMERGENCY VEHICLES TO SAFELY PASS THROUGH THE WORK ZONE. WHEN EMERGENCY ACCESS IS NOT POSSIBLE, THE CONTRACTOR MUST COORDINATE WITH LOCAL EMERGENCY SERVICES TO ENSURE THAT ANY RESTRICTIONS ARE COMMUNICATED TO THE APPROPRIATE EMS PROVIDERS.
- CONTRACTOR SHALL COORDINATE AND ACCOMMODATE OTHER CONTRACTORS PERFORMING WORK IN THE AREA INCLUDING, BUT NOT LIMITED TO: CONSTRUCTION CONTRACTORS IN THE AREA, UTILITY COMPANIES, IRRIGATION DISTRICTS AND/OR COUNTY MAINTENANCE CREWS.
- CONTRACTOR SHALL CONDUCT PRE-CONSTRUCTION SURVEY ACCORDING TO ODOT CONSTRUCTION SURVEYING MANUAL FOR CONTRACTORS, CHAPTER 7, PRIOR TO BEGINNING WORK ONSITE.

(11"X17" PLAN SHEETS ARE REDUCE 50% FROM ORIGINAL SCALE)

REVISIONS	DATE	BY	DESIGNED BY:	TW
			DRAWN BY:	TW
			CHECKED BY:	BW
			APPROVED BY:	CS

SCALE AS SHOWN ABOVE
FILE NAME:
JOB No. W66118
DATE: 01/03/2025

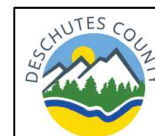

ROAD DEPARTMENT

PROJECT NAME:
WILCOX AVE BRIDGE REMOVAL

SHEET TITLE:
TITLE PAGE

PROJ NO. W66118
PAGE NO. 1

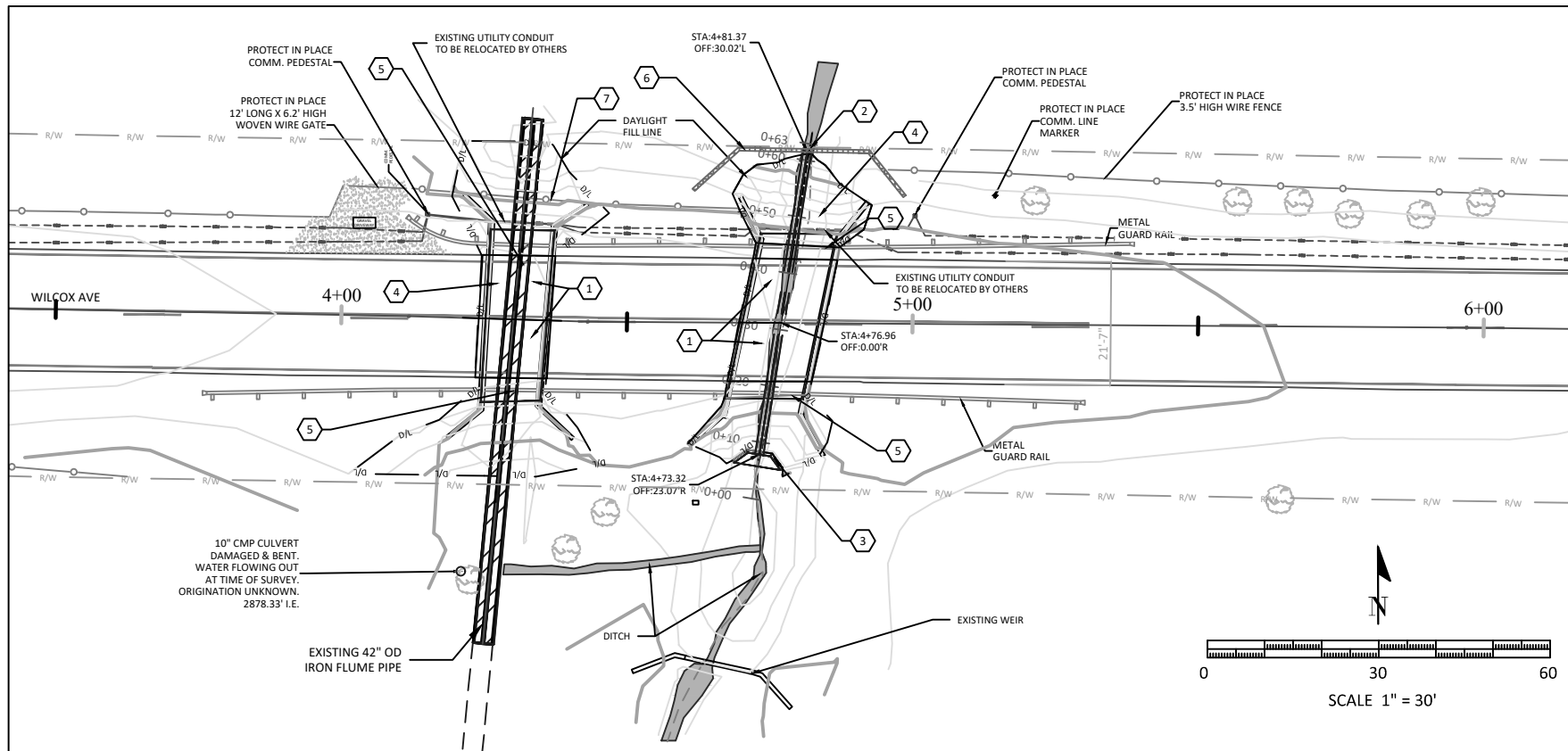

NOTES

- 1) PROTECT EXISTING SURFACINGS AND PAVEMENT MARKINGS OUTSIDE OF WORK LIMITS.
- 2) CONTRACTOR TO VERIFY DEPTH OF EXISTING UTILITIES PRIOR TO EXCAVATION.

- 1 DEMO, REMOVE AND DISPOSE OF THE EXISTING TIMBER BRIDGE AND CONCRETE WINGWALLS ACCORDING TO STATE AND LOCAL LAWS. (ABUTMENTS REMAIN)
WEST BRIDGE - STA 4+25.25 TO STA 4+36.56
EAST BRIDGE - STA 4+70.02 TO STA 4+83.74
- 2 INSTALL 18" HDPE CULVERT PIPE PER PAGE 3
- 3 INSTALL CONCRETE HEADWALL PER PAGE 3
- 4 BACKFILL EXISTING CHANNEL PER PAGE 5
- 5 TEMP REMOVE GUARDRAIL SECTIONS WHILE REMOVING STRUCTURE. LIMITS WILL BE NOTED IN THE FIELD. INSTALL MISSING POST PER ODOT STANDARD DWG. RD406 AND REPLACE RAIL BEFORE OPENING THE ROAD.
- 6 INSTALL TYPE 3 SEDIMENT BARRIER
- 7 REMOVE & REINSTALL EXISTING FENCE

LEGEND

- R/W — RIGHT OF WAY
- EDGE OF ROADWAY
- D/L — DAYLIGHT LINE
- ==== PIPE/CULVERT
- FENCE
- - - - DITCH BOTTOM
- BRIDGE DECK

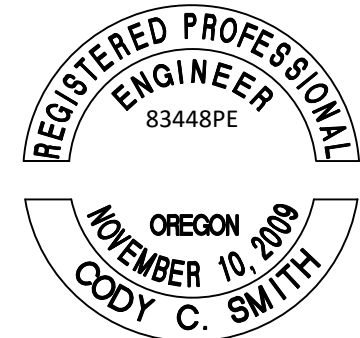
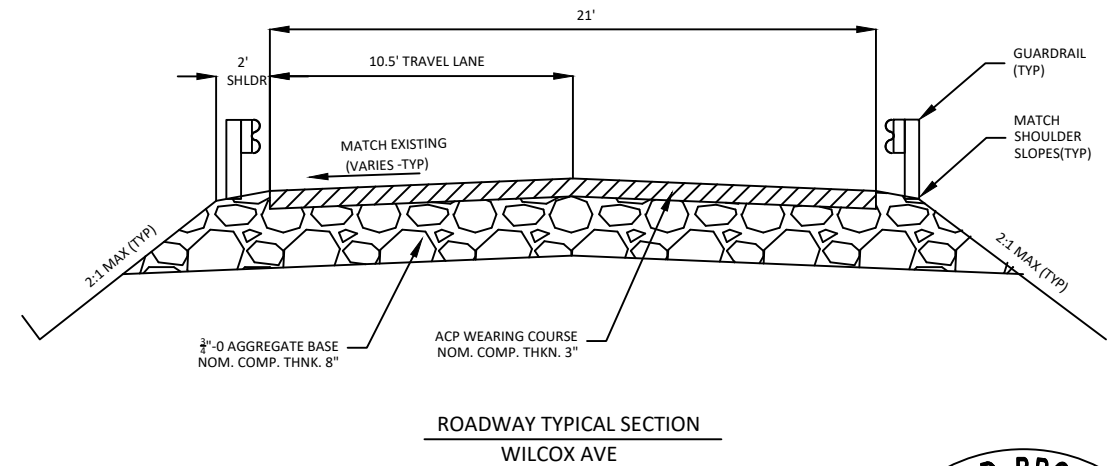
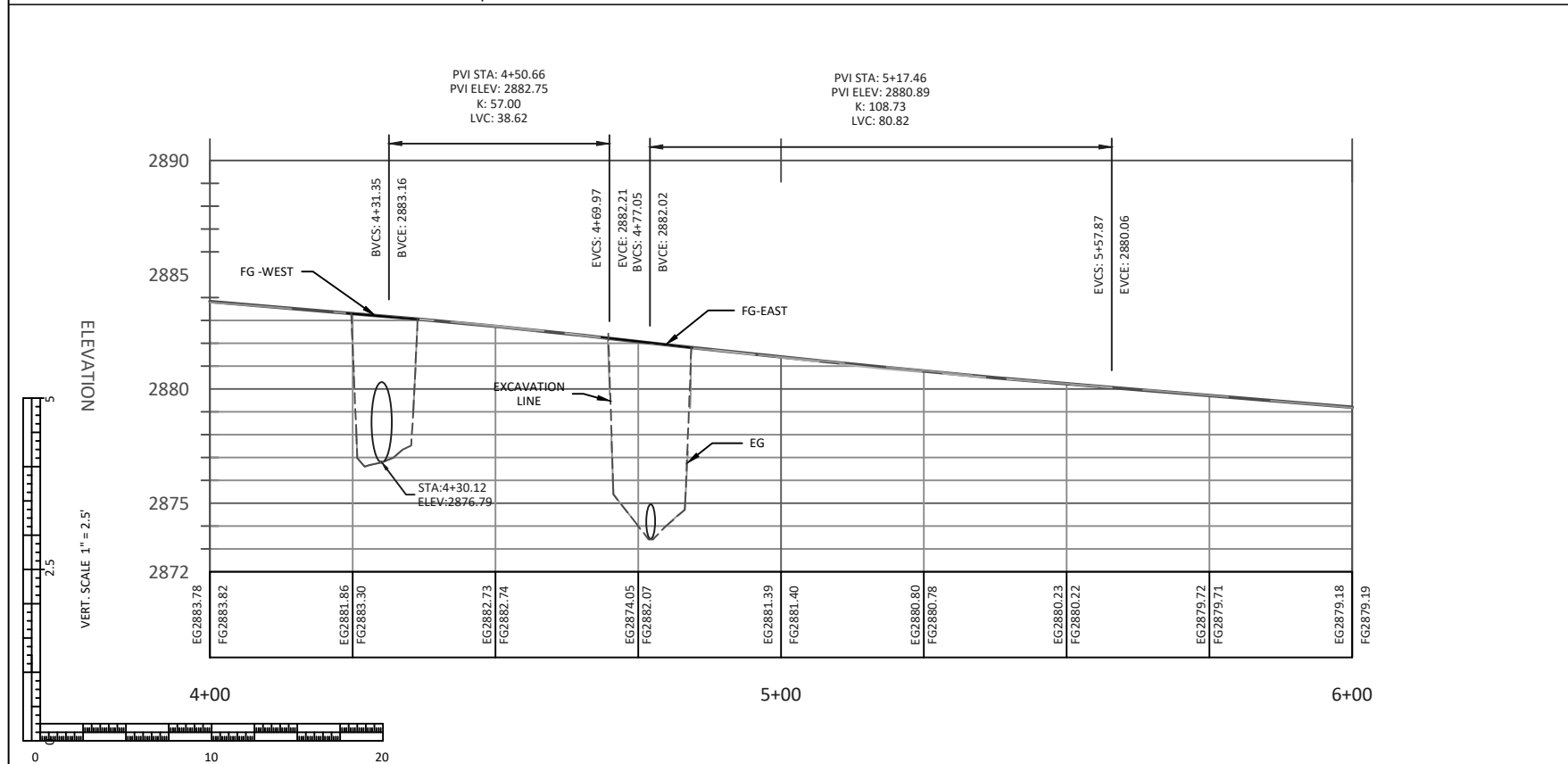
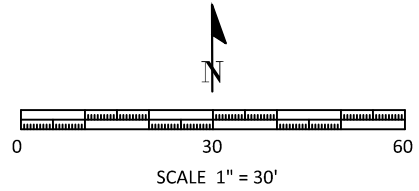

RENEWS: 06/30/2026

(11"x17" PLAN SHEETS ARE REDUCE 50% FROM ORIGINAL SCALE)

REVISIONS	DATE	BY	DESIGNED BY:	SCALE AS SHOWN ABOVE
			TW	FILE NAME:
			TW	JOB No. W66118
			BW	DATE: 01/03/2025
			CS	



PROJECT NAME:
WILCOX AVE BRIDGE REMOVAL

SHEET TITLE:
WILCOX AVE - PLAN AND PROFILE

PROJ. NO. W66118
PAGE NO. 2

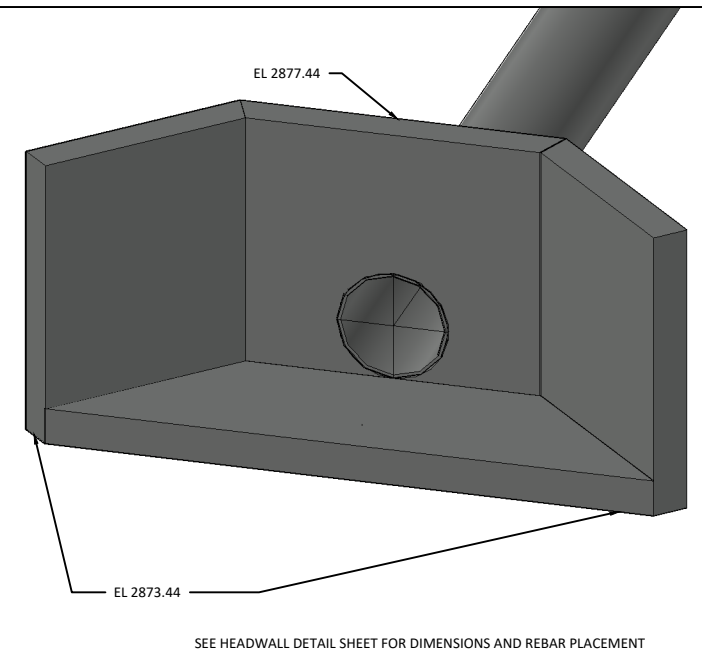
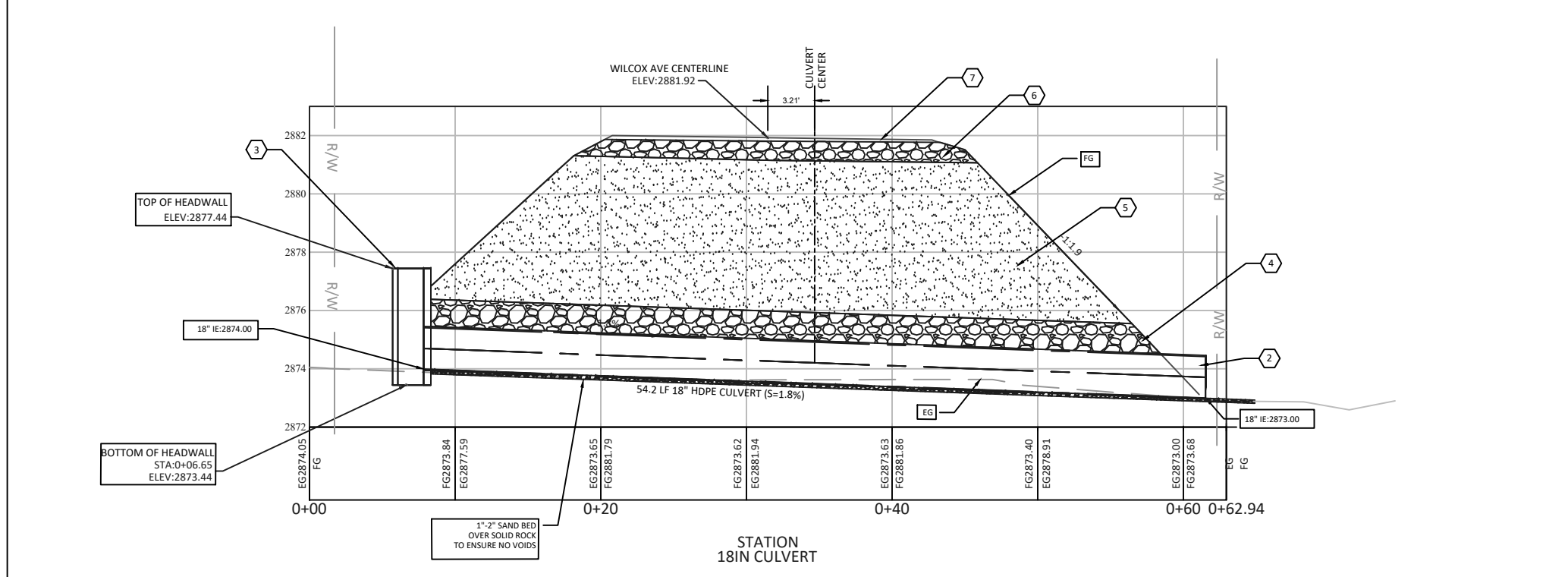
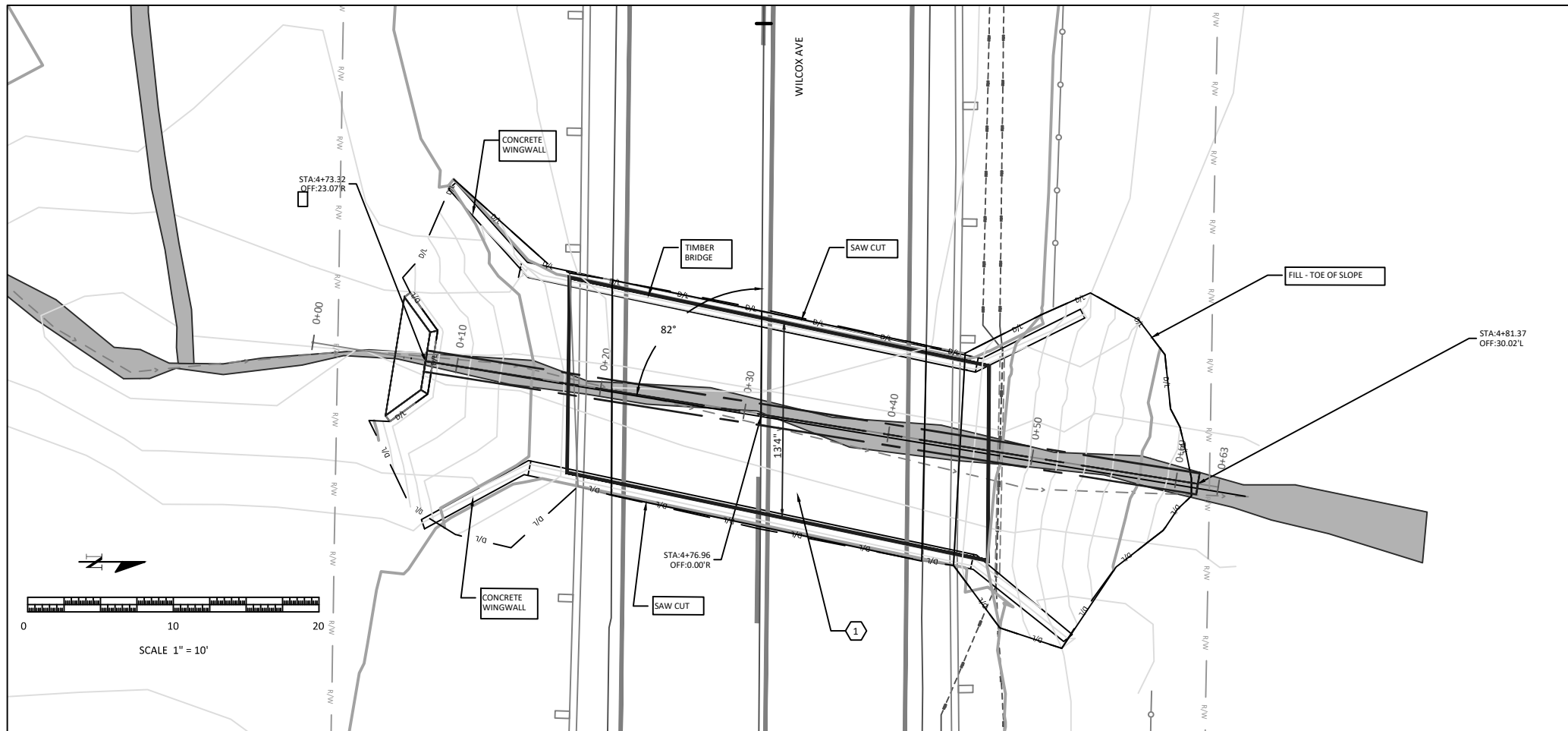

SEE HEADWALL DETAIL SHEET FOR DIMENSIONS AND REBAR PLACEMENT

- 1 DEMO, REMOVE AND DISPOSE OF THE EXISTING TIMBER BRIDGE AND CONCRETE WINGWALLS ACCORDING TO STATE AND LOCAL LAWS. (ABUTMENTS TO REMAIN)
- 2 INSTALL 18" HDPE CULVERT -54.2' IN LENGTH
INLET - STA: 4+73.10
OFFSET: 24.54' R
I.E. 2874.00
OUTLET - STA: 4+82.20
OFFSET: 33.28' L
I.E. 2873.00
- 3 INSTALL 4' (HIGH) X 6" (THICK) CONCRETE HEADWALL
BOTTOM ELEVATION: 2873.44
TOP ELEVATION: 2877.44
INSERT DOWELS - 6"-12" INTO SOLID ROCK.
SEE RD339 FOR STRUCTURE CONNECTION DETAIL
- 4 INSTALL PIPE BEDDING AND PIPE COVER PER TRENCH DETAIL SHEET
- 5 BACKFILL BETWEEN PIPE COVER AND AGG BASE WITH FILL TO 95% MOD PROCTOR
- 6 INSTALL AGG BASE - NOM. THKN. 8"
- 7 LEVEL 3 (1/4" DENSE) ACP - NOM. THKN. 3"

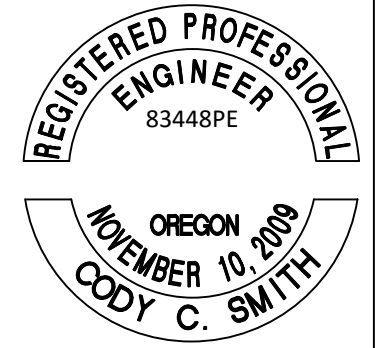

RENEWS: 06/30/2026

(11"x17" PLAN SHEETS ARE REDUCE 50% FROM ORIGINAL SCALE)

REVISIONS	DATE	BY	DESIGNED BY:	SCALE AS SHOWN ABOVE
			TW	FILE NAME: W66118 DESIGN
			TW	JOB No. W66118
			BW	DATE: 01/03/2025
			CS	



PROJECT NAME:
WILCOX AVE BRIDGE REMOVAL

SHEET TITLE:
CULVERT - PLAN AND PROFILE

PROJ NO.
W66118
PAGE NO.
3

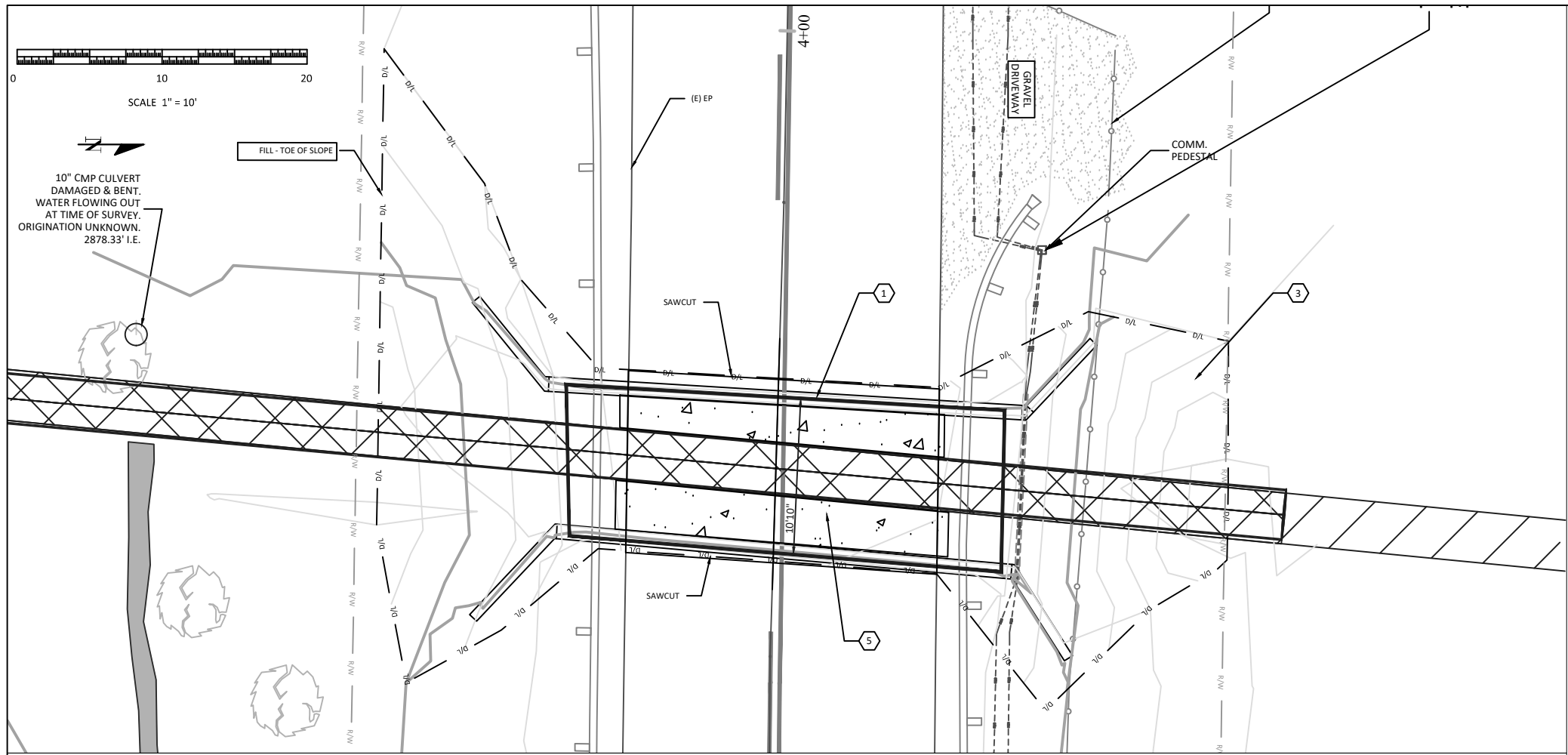

NOTES

1) PROTECT EXISTING FLUME PIPE IN PLACE

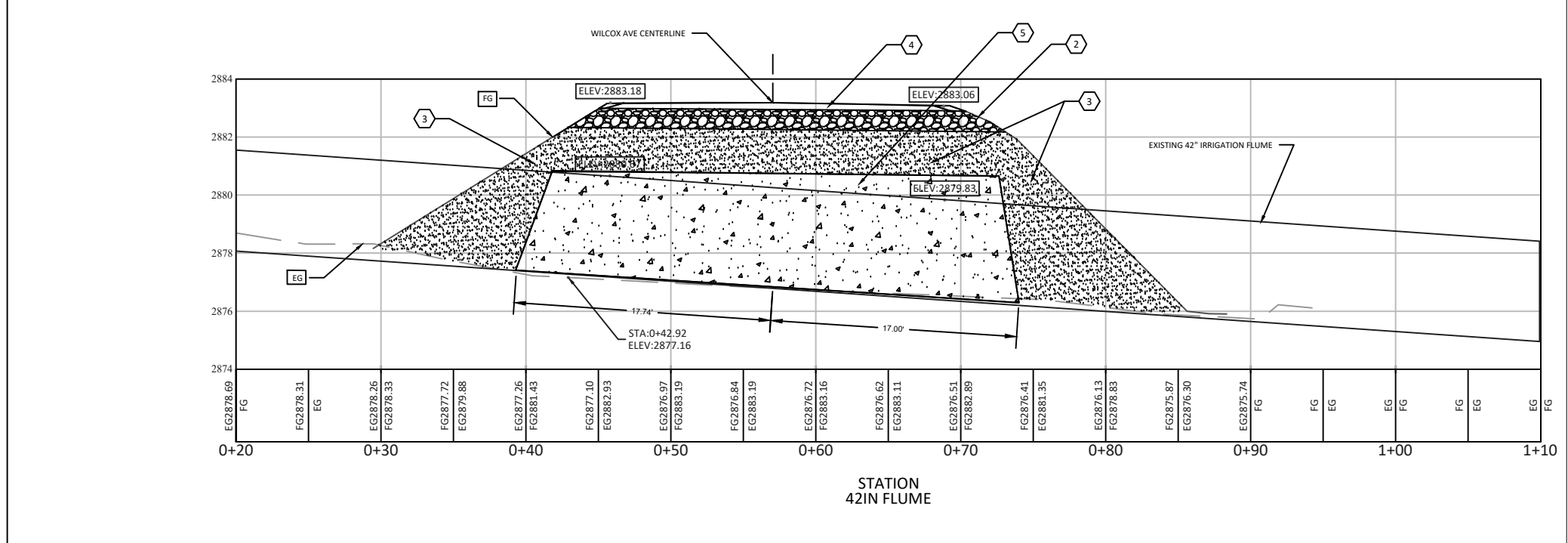

- 1 DEMO, REMOVE AND DISPOSE OF THE EXISTING TIMBER BRIDGE AND CONCRETE WINGWALLS ACCORDING TO STATE AND LOCAL LAWS. (ABUTMENTS REMAIN)
- 2 INSTALL 3/4" O AGG BASE - NOM. THKN. 8"
- 3 BACKFILL SIDESLOPES WITH FILL
- 4 LEVEL 3 (3/4" DENSE) ACP, NOM. THKN. 3"
- 5 BACKFILL AROUND EXISTING 42" IRRIGATION FLUME WITH CLSM UNDER ROADWAY STRUCTURE

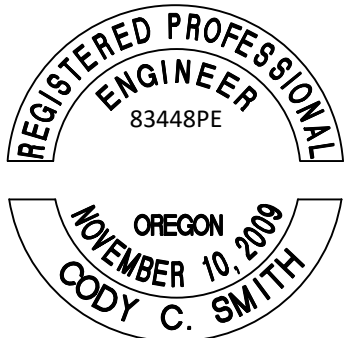

RENEWS: 06/30/2026

(11"x17" PLAN SHEETS ARE REDUCE 50% FROM ORIGINAL SCALE)

REVISIONS	DATE	BY	DESIGNED BY:
			TW
			DRAWN BY:
			TW
			CHECKED BY:
			BW
			APPROVED BY:
			CS

SCALE AS SHOWN ABOVE
FILE NAME: W66118 DESIGN
JOB No. W66118
DATE: 01/03/2025



PROJECT NAME:
WILCOX AVE BRIDGE REMOVAL

SHEET TITLE:
FLUME - PLAN AND PROFILE

PROJ NO.
W66118
PAGE NO.
4

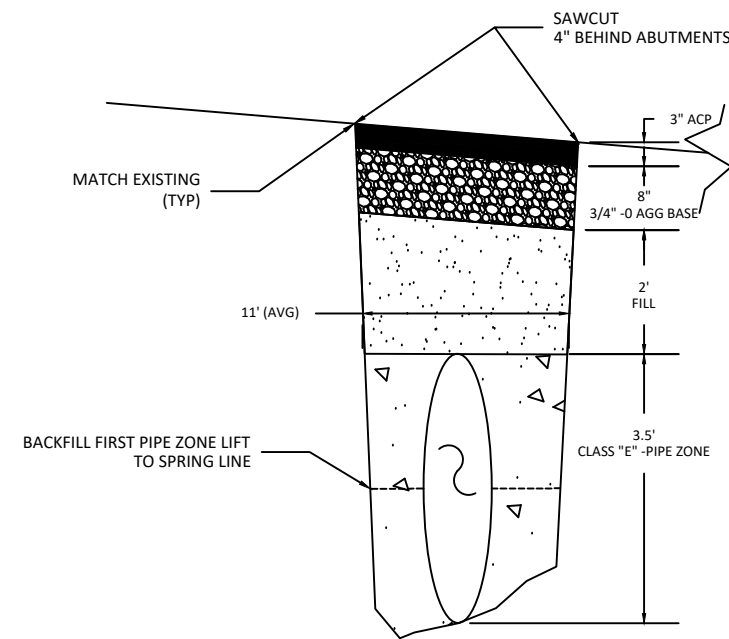

WEST TRENCH

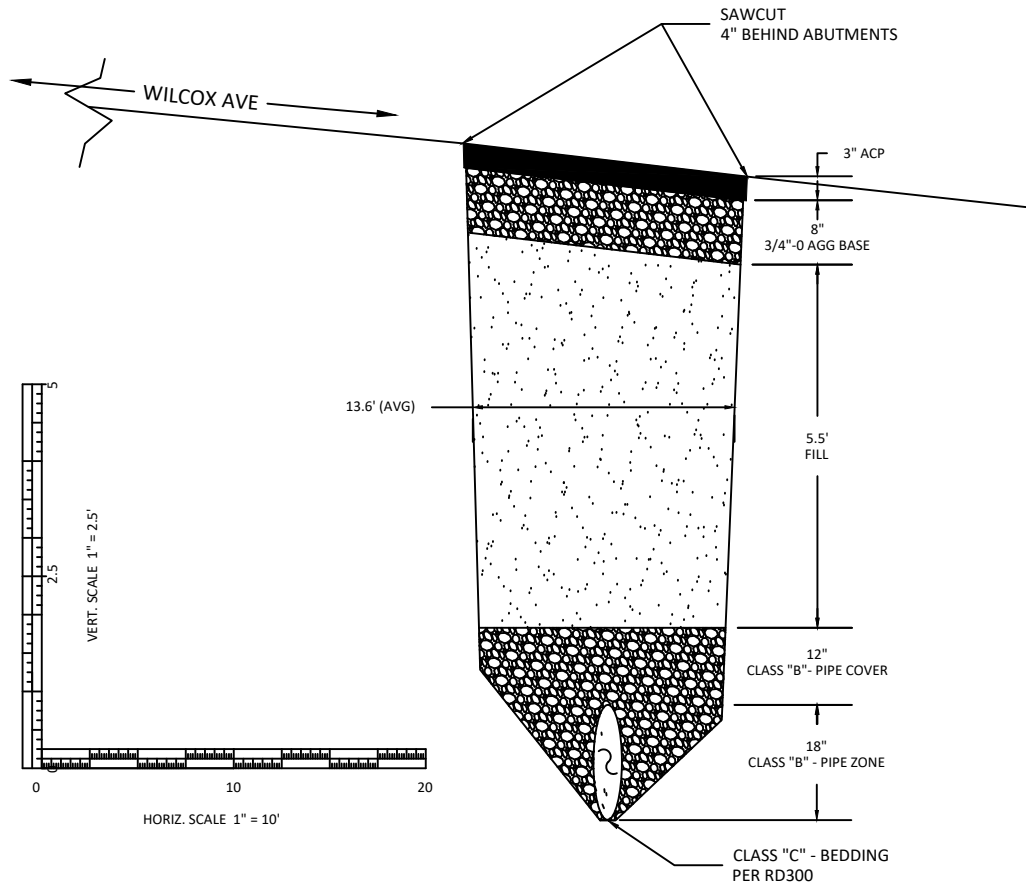

EAST TRENCH

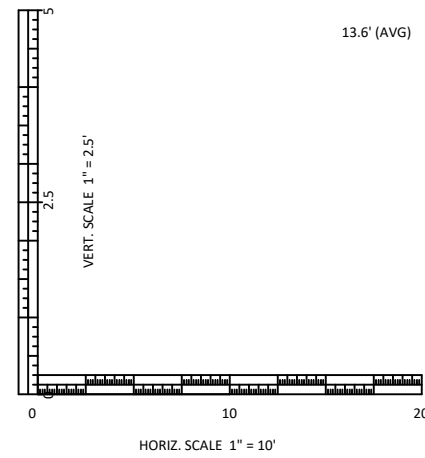

NOTES

- 1) CLASS "B" BACKFILL: 3/4"-0 AGGREGATE BASE. REJECT BASE MATERIAL MAY BE USED ON APPROVAL BY THE ENGINEER.
- 2) CLASS "C" BACKFILL: CLEAN SAND WITH NO PARTICLE SIZE LARGER THAN 1/4" AND NOT MORE THAN 10% BY WEIGHT OF MATERIAL PASSING THE #200 SIEVE.
- 3) CLASS "E" BACKFILL: CONTROLLED LOW STRENGTH MATERIAL CONFORMING TO OSSC 00442
- 4) RESTRAIN STEEL FLUME AS REQUIRED TO FACILITATE BACKFILLING WITHOUT FLOATING
- 5) FOR DETAILS NOT SHOWN, SEE OREGON STD. DWG. RD300

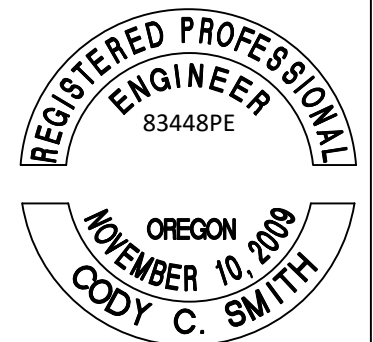

RENEWS: 06/30/2026

(11"x17" PLAN SHEETS ARE REDUCE 50% FROM ORIGINAL SCALE)

REVISIONS	DATE	BY	DESIGNED BY:
			TW
			DRAWN BY: TW
			CHECKED BY: BW
			APPROVED BY: CS

SCALE AS SHOWN ABOVE
FILE NAME: W66118 DESIGN
JOB No. W66118
DATE: 01/03/2025



PROJECT NAME:	WILCOX AVE BRIDGE REMOVAL
---------------	---------------------------

SHEET TITLE:	TRENCH DETAILS
--------------	----------------

PROJ NO.	W66118
PAGE NO.	5

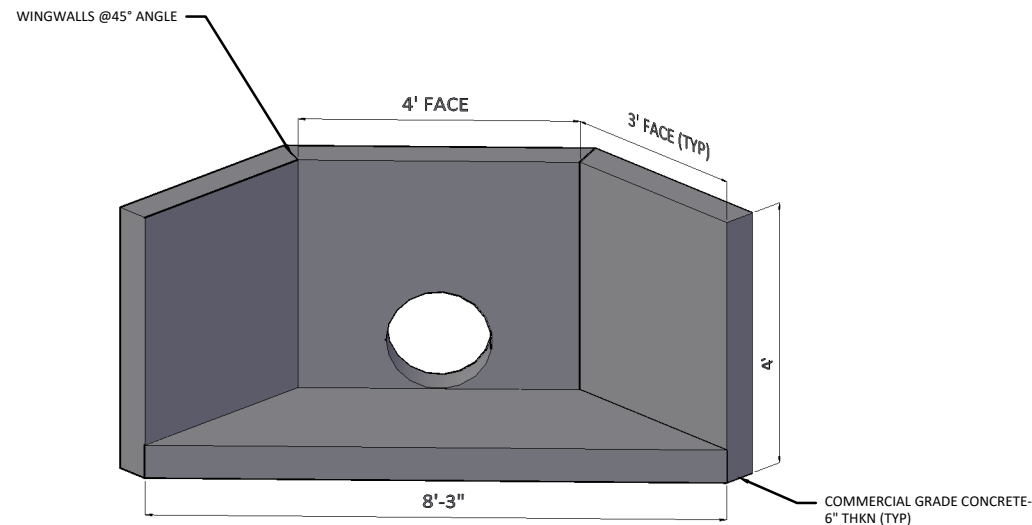

BENT BAR LIST									
BAR MARK	QTY	SIZE	TOTAL LENGTH	TYPE	'A'	'B'	'C'	'D'	'E'
4B01	4	#4	5'-9"	11	1'-6"	3'-7"			
4B02	6	#4	5'-9"	11	2'-2"	3'-7"			
4B03	1	#4	5'-8"	25	2'-6"	2'-6"	1'-8 1/4"	1'-8 1/4"	0'-8"

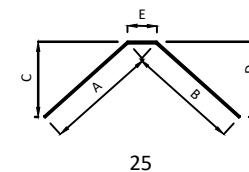
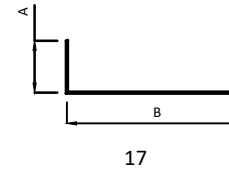

LEGEND

- TB - TOP AND BOTTOM HORIZONTAL BAR IN WALL
- CENT - CENTER HORIZONTAL BARS IN WALL
- VC - VERTICAL CORNER BAR
- THF - TOP HORIZONTAL FLOOR BAR
- BHF - BOTTOM HORIZONTAL FLOOR BAR

NOTES:

1. ALL REINFORCEMENT IS OF GRADE A615/60
2. BARS TO BE PLACED AT EQUAL SPACING UNLESS OTHERWISE NOTED.
3. LAP SCHEDULE BTWN #4B01 AND THF IS 9"
4. MIN 2" CONCRETE COVER OVER REBAR

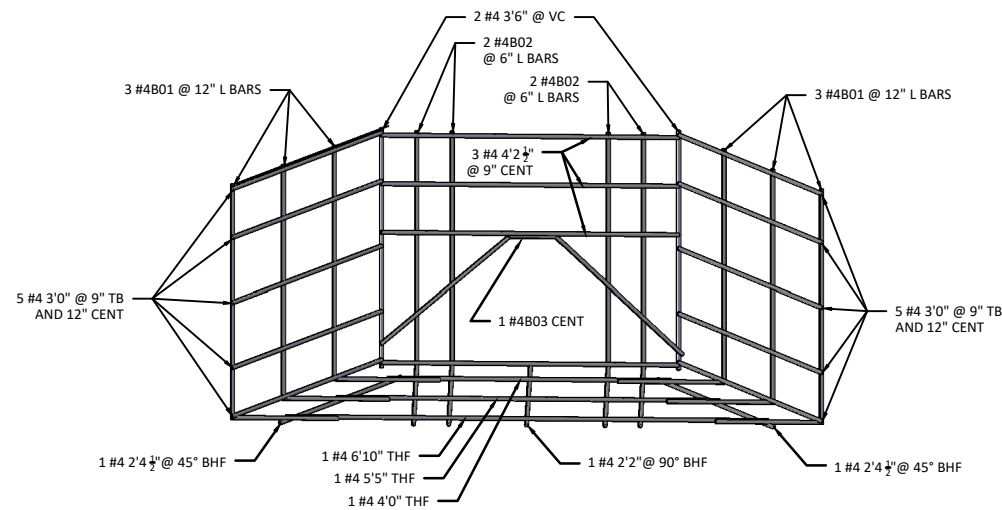

(11"x17" PLAN SHEETS ARE REDUCE 50% FROM ORIGINAL SCALE)

REVISIONS	DATE	BY	DESIGNED BY:	SCALE AS SHOWN ABOVE
			TW	FILE NAME: W66118 HEADWALL
			DRAWN BY: TW	JOB No. W66118
			CHECKED BY: BW	DATE: 01/03/2025
			APPROVED BY: CS	

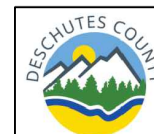

ROAD DEPARTMENT

PROJECT NAME: WILCOX AVE BRIDGE REMOVAL
--

SHEET TITLE: HEADWALL DETAIL

PROJ NO. W66118
PAGE NO. 6

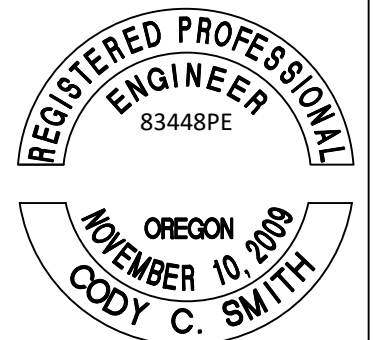

RENEWS: 06/30/2026

TABLE A

"A" (in)	"B" (in)	"C" (in)	"D" (in)
4	10	4	8
6	10	4	8
8	10	6	10
10	10	6	10
12	12	6	10
15	12	6	10
18	16	6	12
21	16	6	12
24	18	6	12
30	18	6	12
36	24	6	14
42	24	6	14
48	24	6	14
54	24	6	14
60	24	6	14
66	24	6	14
72	24	6	14

For pipes over 72" diameter, see general note 3.

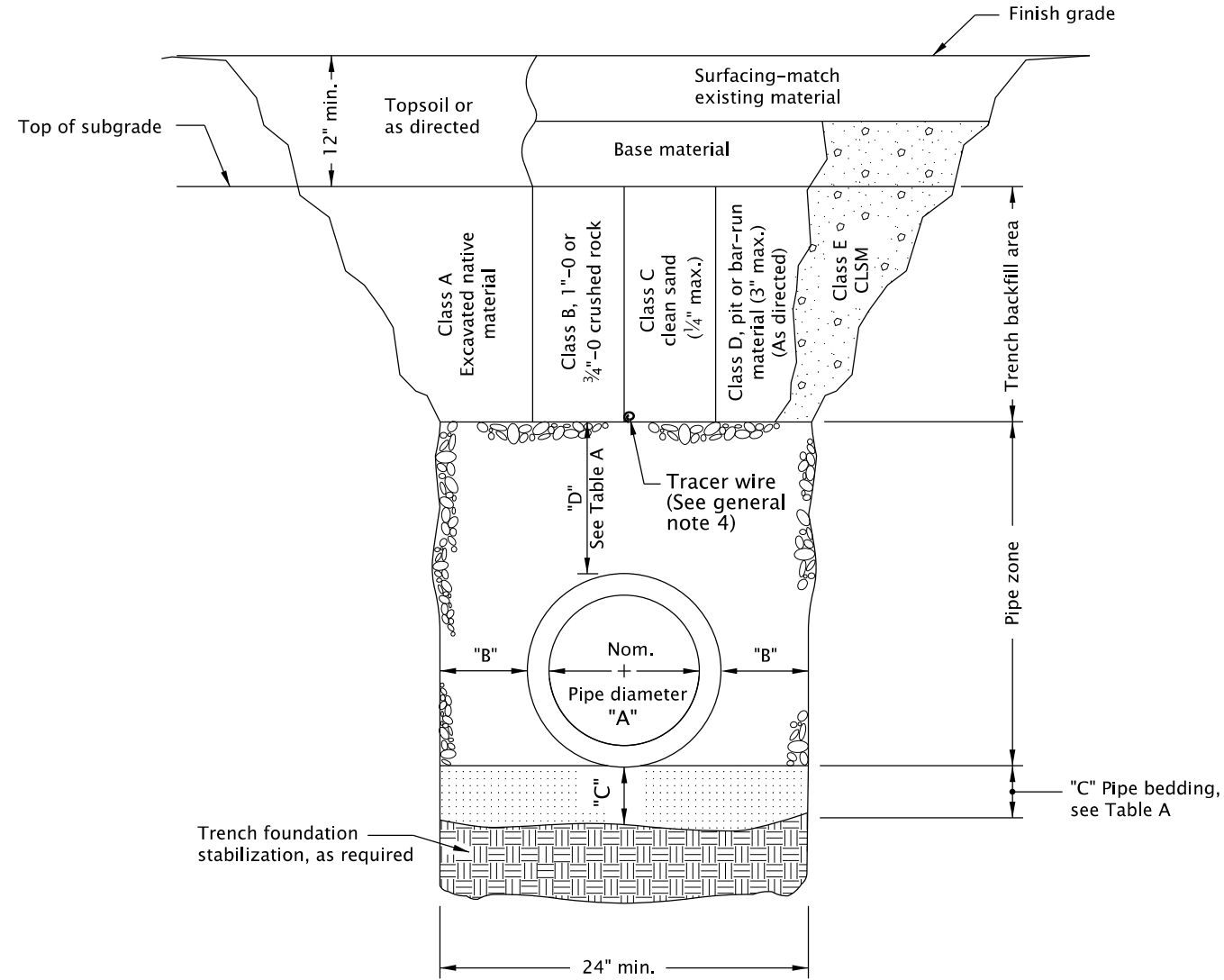

MULTIPLE INSTALLATIONS	
DIAMETER	MIN. SPACE BETWEEN PIPES
Up to 48"	24"
48" to 72"	One half (1/2) dia. of pipe

GENERAL NOTES FOR ALL DETAILS ON THIS SHEET:

1. Surfacing of paved areas shall comply with street cut Std. Dwg. RD302.
2. For pipe installation in embankment areas where the trench method will not be used and the pipe is ≥ 36 " diameter, increase dimension "B" to nominal pipe diameter.
3. Pipes over 72" diameter are structures, and are not applicable to this drawing.
4. See Std. Dwg. RD336 for tracer wire details (When required).

The selection and use of this Standard Drawing, while designed in accordance with generally accepted engineering principles and practices, is the sole responsibility of the user and should not be used without first consulting a Registered Professional Engineer.

All materials shall be in accordance with the current Oregon Standard Specifications.

OREGON STANDARD DRAWINGS
TRENCH BACKFILL, BEDDING,
PIPE ZONE AND MULTIPLE
INSTALLATIONS

2024

DATE	REVISION	DESCRIPTION
CALC. BOOK NO. --- N/A ---	SDR DATE-- 14-JUL-2014 --	RD300

20-JAN-2023

RD339.dgn

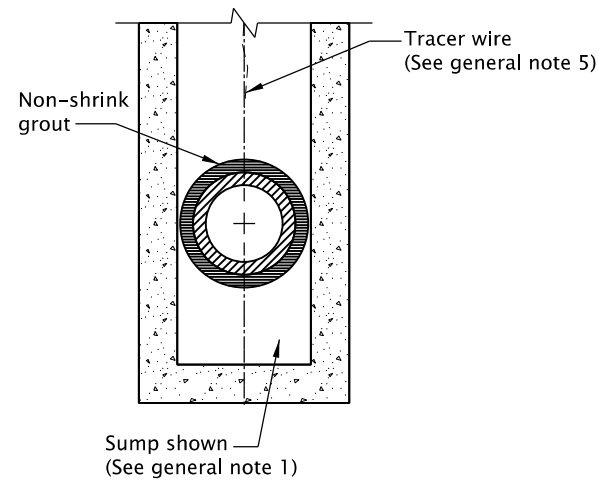

SECTION B-B

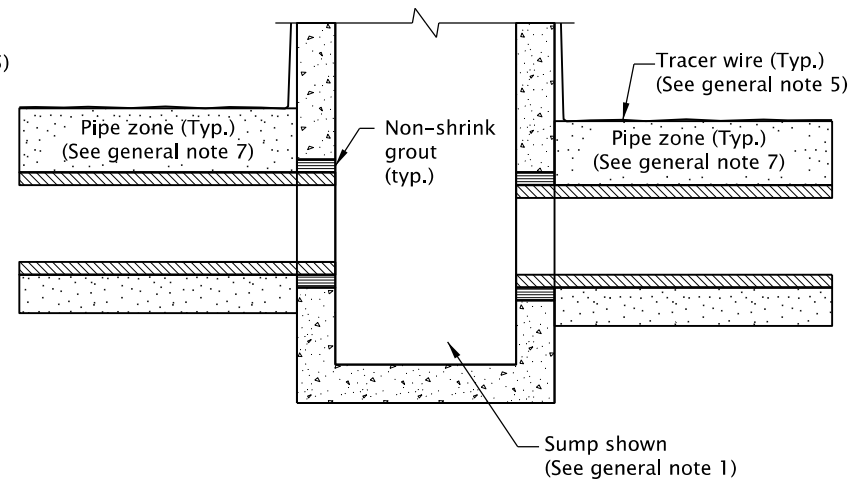

SECTION A-A

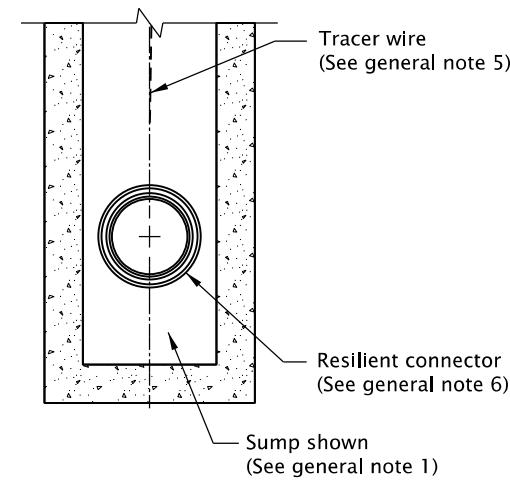

SECTION D-D

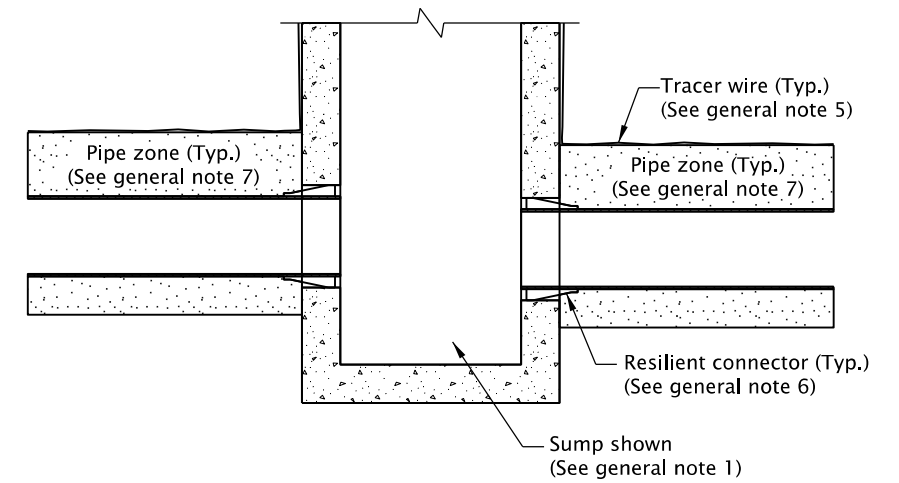

SECTION C-C

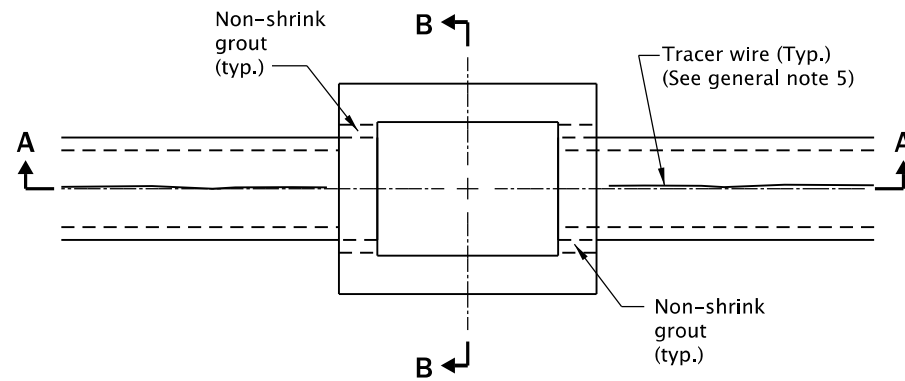

PLAN

CONNECTION OF RIGID PIPE TO STRUCTURE

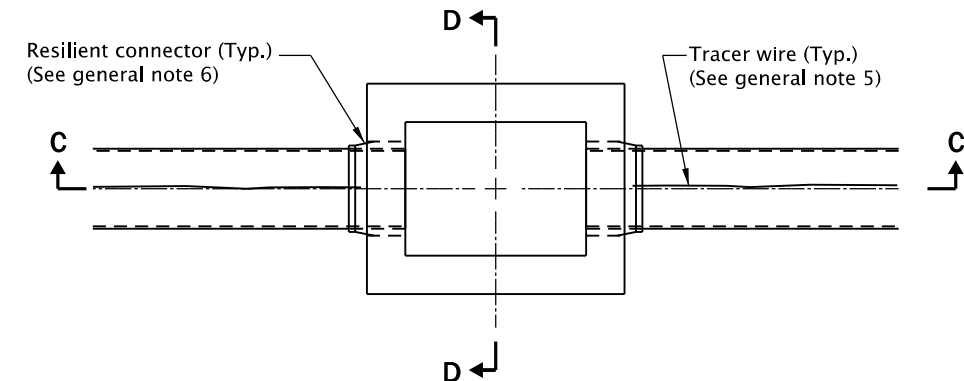

PLAN

CONNECTION OF FLEXIBLE PIPE TO STRUCTURE

GENERAL NOTES FOR ALL DETAILS ON THIS SHEET:

1. See Std. Dwgs. RD364, RD365, and RD366 for inlet details not shown.
2. See appropriate standard drawings or special project details for other similar structures.
3. Location, elevation, diameter, slope, and number of pipe(s) varies, see project plans.
4. Maximum pipe diameter varies with pipe material.
5. All connecting pipes shall have a tracer wire, or approved alternate. See Std. Dwg. RD336 for tracer wire details.
6. When flexible pipe is used, install resilient connectors conforming to requirements of ASTM C923.
7. Pipe zone varies, see Std. Dwg. RD300.

<p><i>The selection and use of this Standard Drawing, while designed in accordance with generally accepted engineering principles and practices, is the sole responsibility of the user and should not be used without first consulting a Registered Professional Engineer.</i></p>		All materials shall be in accordance with the current Oregon Standard Specifications.	
		OREGON STANDARD DRAWINGS	
		PIPE TO STRUCTURE CONNECTIONS	
		2024	
DATE	REVISION	DESCRIPTION	
07-2021	REVISED NOTES		
04-2022	REVISED NOTES		
01-2023	REVISED DETAILS AND NOTES		
CALC. BOOK NO.	N/A	SDR DATE	20-JAN-2023
			RD339

Effective Date: June 1, 2024 – November 30, 2024

RD403.dgn 19-JUL-2021

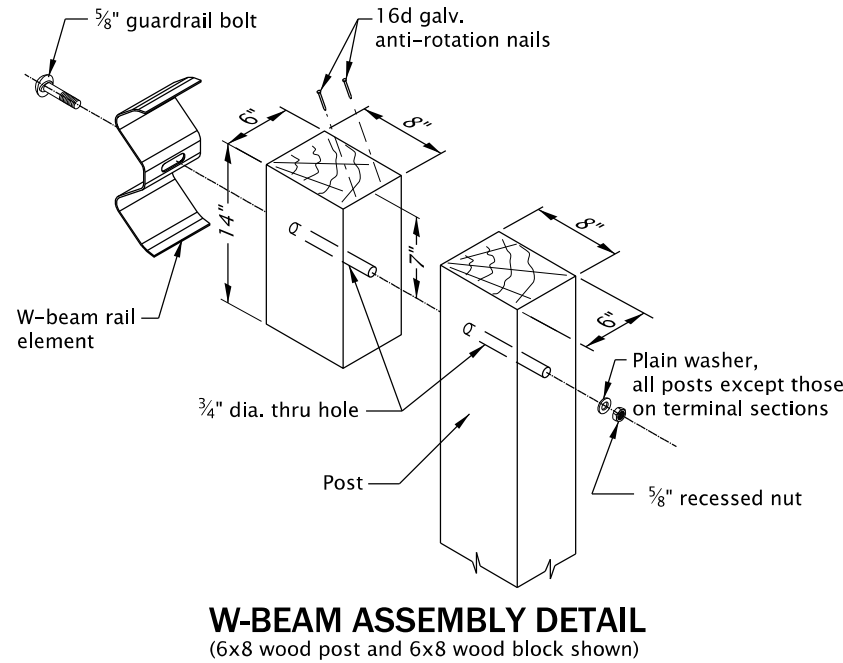
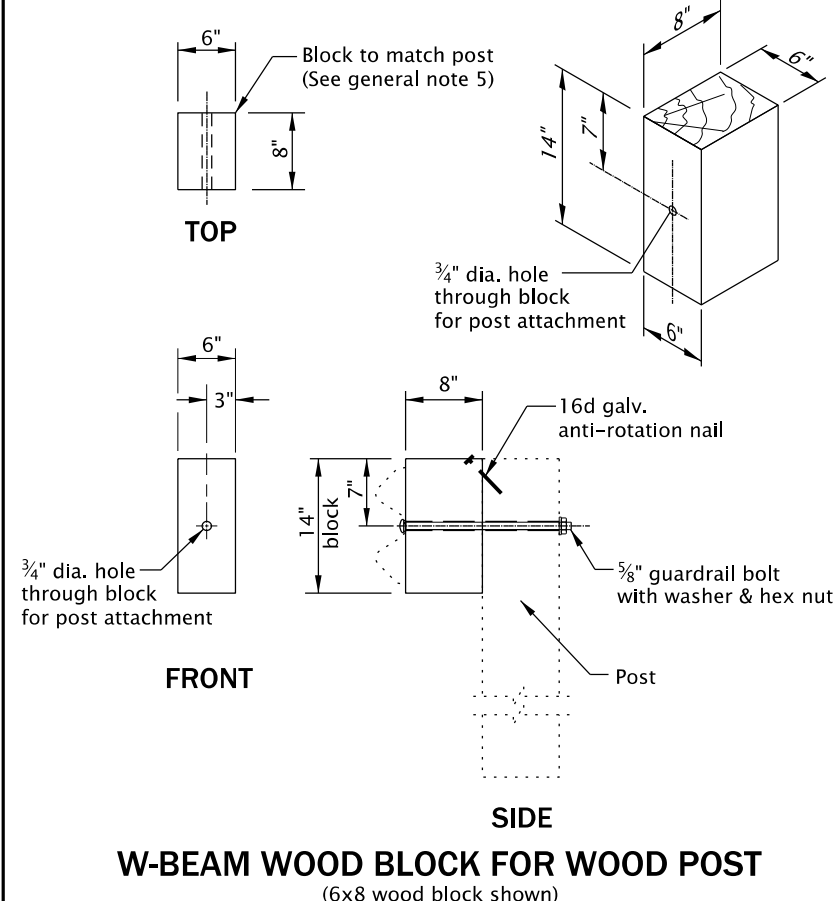
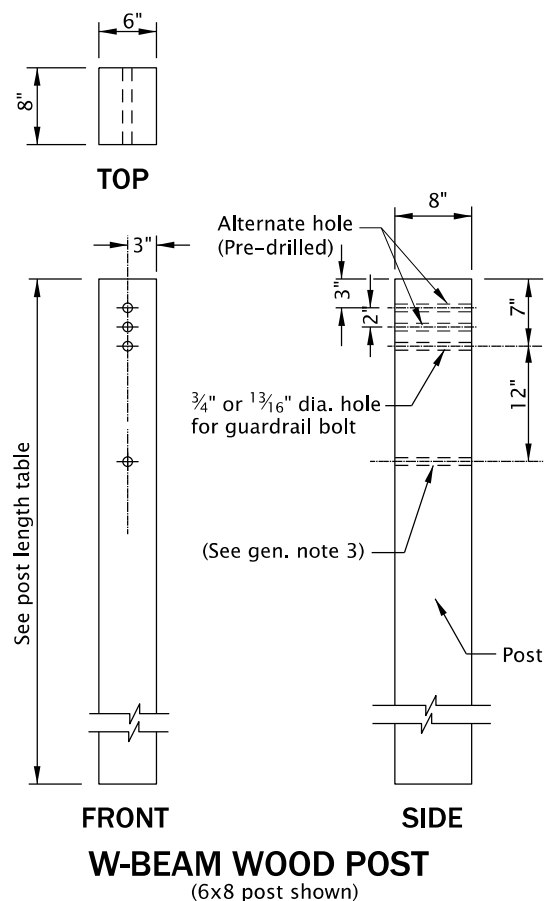

- GENERAL NOTES FOR ALL DETAILS ON THIS SHEET:
1. See appropriate guardrail standard drawing(s) for details not shown.
 2. See Bridge Dwgs. for bridge transition guardrail post and block requirements.
 3. Lowest hole(s) required only when channel rail is to be installed. Drill 12" below top 3/4" or 1 3/16" hole(s) used.
 4. Dimensions shown are for nominal posts and blocks.
 5. Wood blocks shown. Blocks of an approved alternate material may be used. See ODOT's QPL.
 6. When required by the plans, nested thrie beam wood post shall be 8"x8".
 7. Wood block shall be toe-nail to the post with 2 - 16d galvanized nails in top of block to prevent block rotation.

GUARDRAIL WOOD POST TABLE				
	GUARDRAIL TYPE	POST SIZE	POST LENGTH	POST SPACING
W-BEAM	2A	6"x8" or 8"x8"	6'-0"	6'-3"
	3	8"x8"	6'-0"	3'-1 1/2"
	Metal median barrier	8"x8"	6' 6"	6'-3"
THRIE BEAM	4	6"x8" or 8"x8"	7'-0"	6'-3"
	4 (Transition)	8"x8"	6'-0"	3'-1 1/2"

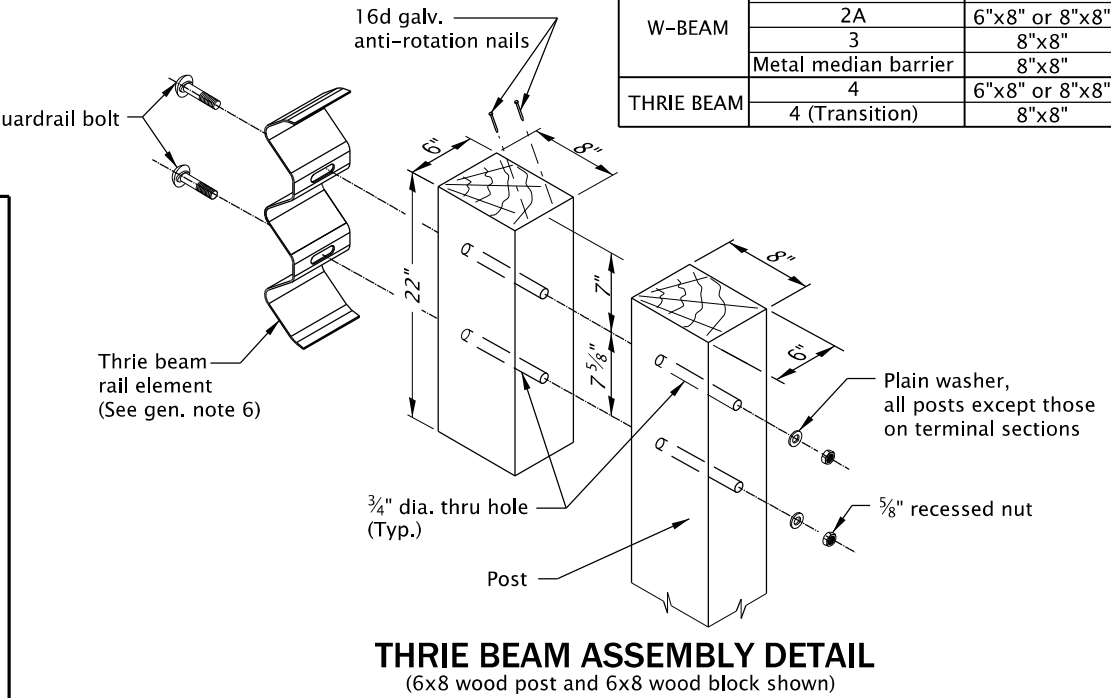
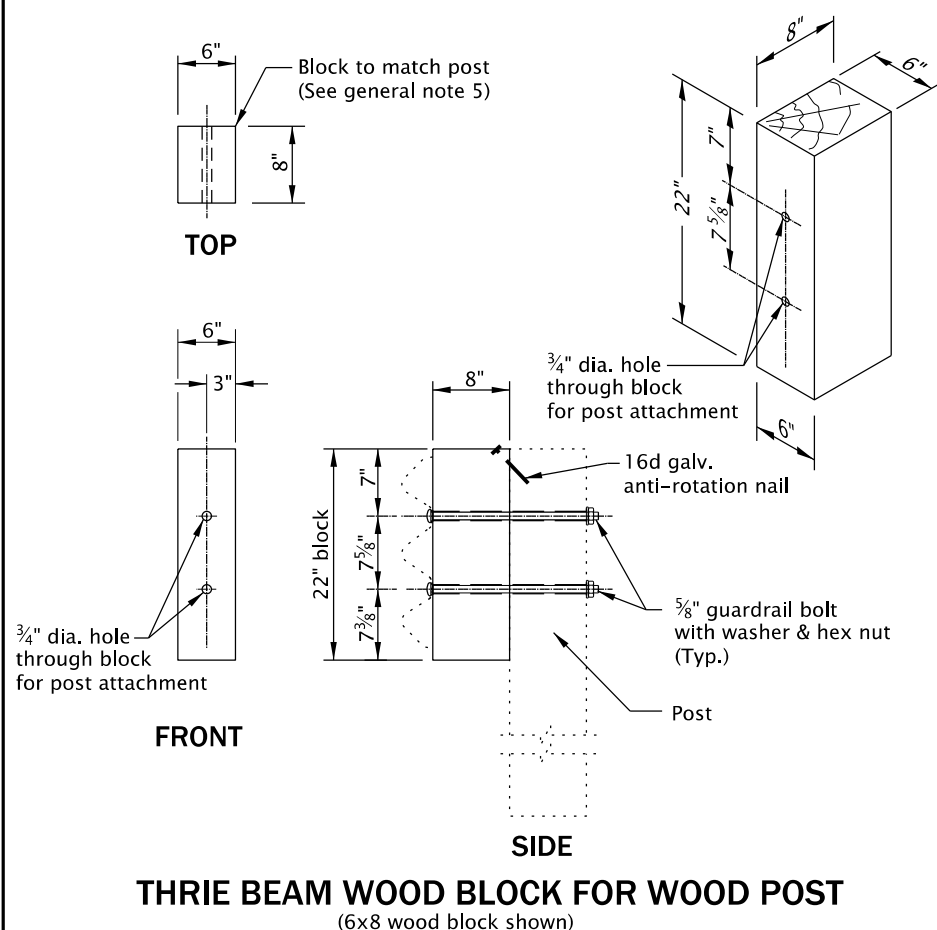
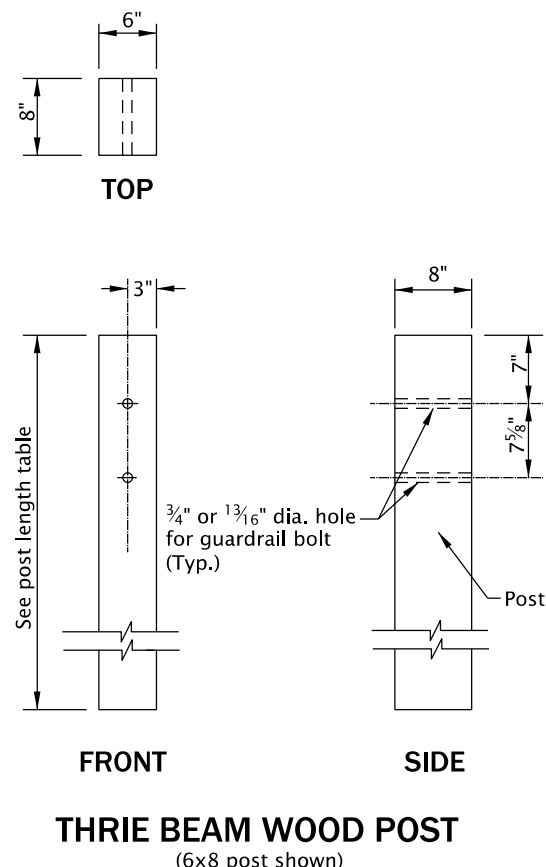

The selection and use of this Standard Drawing, while designed in accordance with generally accepted engineering principles and practices, is the sole responsibility of the user and should not be used without first consulting a Registered Professional Engineer.

All materials shall be in accordance with the current Oregon Standard Specifications.

OREGON STANDARD DRAWINGS

MIDWEST GUARDRAIL SYSTEM WOOD POST AND BLOCK

2024

DATE	REVISION	DESCRIPTION
07-2021	REVISED DETAILS AND NOTES	

CALC. BOOK NO. --- N/A --- SDR DATE: 19-JUL-2021 **RD403**

20-JAN-2023
RD406.dgn

GENERAL NOTES FOR ALL DETAILS ON THIS SHEET:

1. See appropriate guardrail standard drawing(s) for details not shown.
2. Wood blocks shown. Blocks of an approved alternate material may be used. See ODOT's QPL.
3. All posts for guardrail run shall be of the same type: wood or steel.

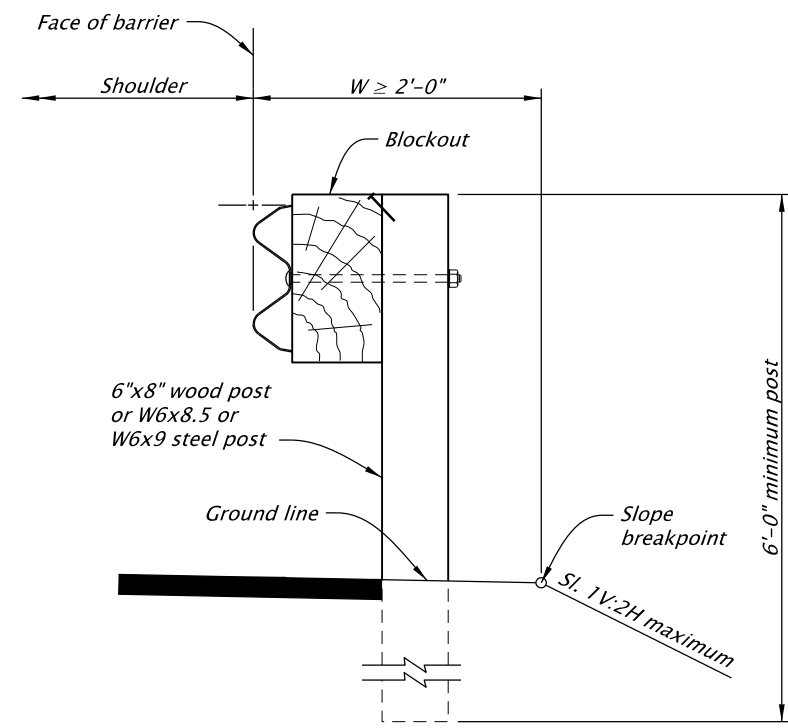

CASE 1
(Wood post shown)

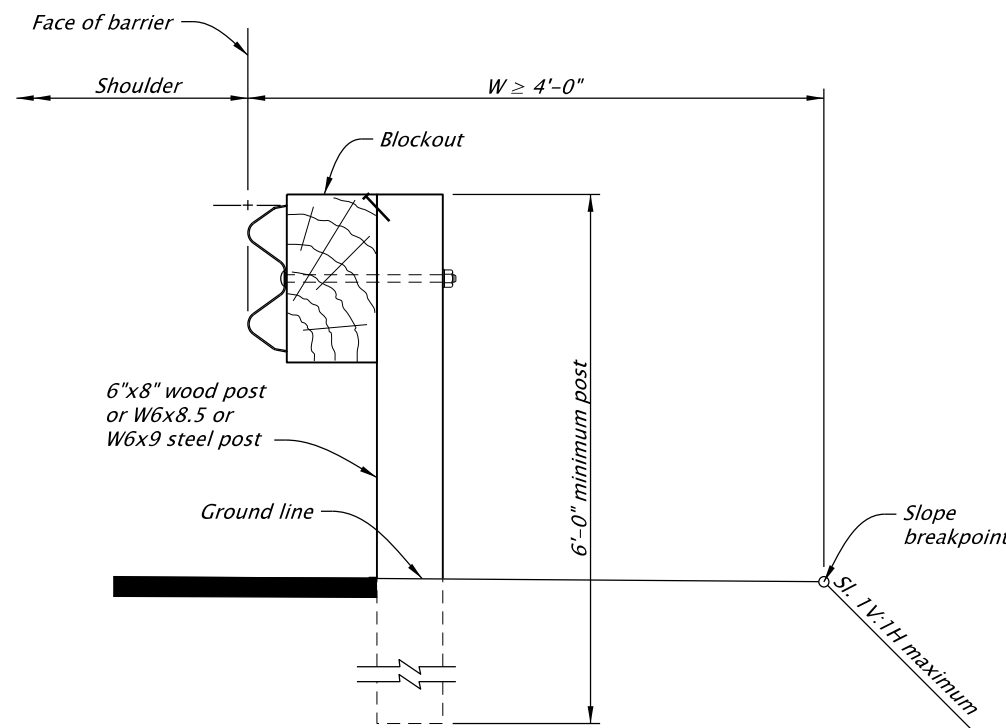

CASE 2
(Wood post shown)
Use when there is a 4'-0" or greater shoulder widening from face of guardrail to the slope breakpoint

SLOPE / EMBANKMENT TABLE			
POST LENGTH (ft)	POST TYPE	SLOPE (V:H)	W (ft) (Face of barrier to slope of breakpoint)
6	Wood/Steel	1:2 or flatter	2'-0" minimum
6	Wood/Steel	1:1 or flatter	4'-0" minimum
8	Wood/Steel	1:1 or flatter	2'-6" minimum
8	Steel	1:1½ or flatter	Less than 2'-0"

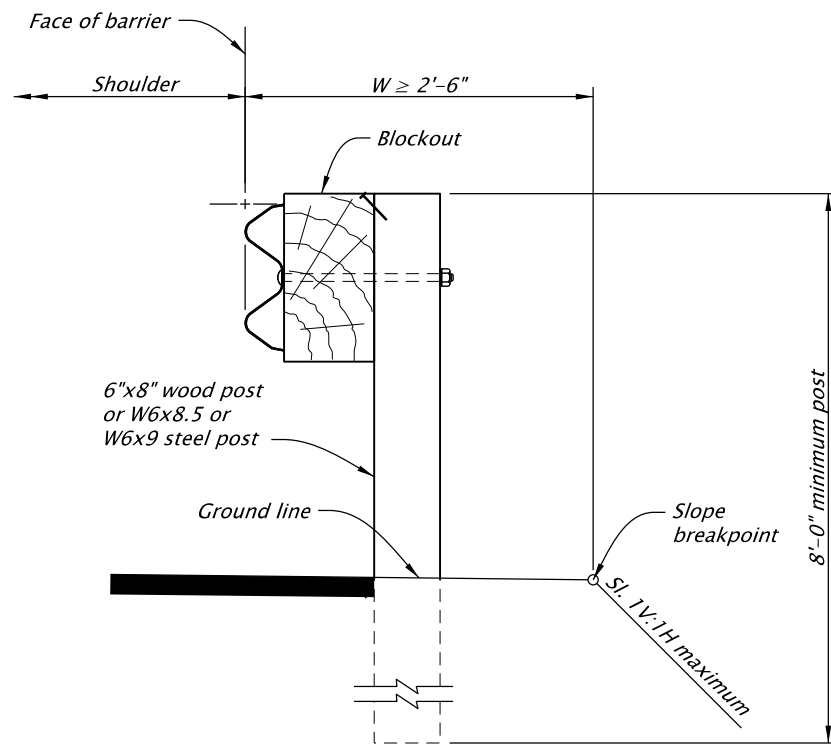

CASE 3
(Wood post shown)
Use when there is a 2'-6" or greater shoulder widening from face of guardrail to the slope breakpoint

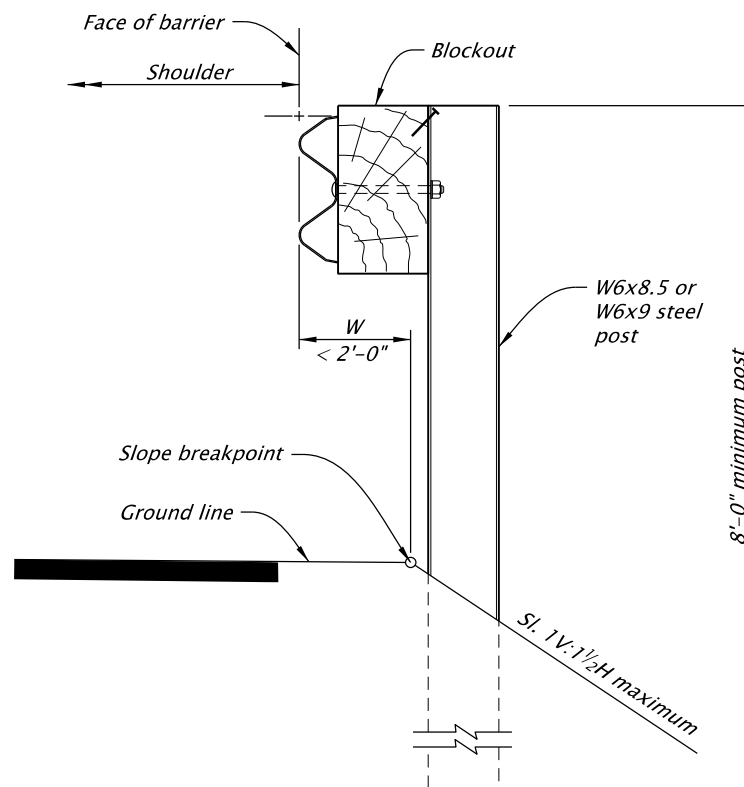

CASE 4
(Steel post shown)
Do not use in weak soil conditions.
Use when there is less than a 2'-0" shoulder widening from face of guardrail to the slope breakpoint

PLACEMENT OF GUARDRAIL ON SLOPES

NOTE: Cases shown do not apply to terminals, transition sections or anchors.

The selection and use of this Standard Drawing, while designed in accordance with generally accepted engineering principles and practices, is the sole responsibility of the user and should not be used without first consulting a Registered Professional Engineer.

All materials shall be in accordance with the current Oregon Standard Specifications.			
OREGON STANDARD DRAWINGS			
PLACEMENT OF GUARDRAILS ON SLOPES			
2024			
DATE	REVISION DESCRIPTION		
07-2021	NEW DRAWING CREATED		
12-2021	REVISED DETAILS AND NOTES		
12-2022	REVISED NOTE		
CALC. BOOK NO.	N/A	SDR DATE	20-JAN-2023
			RD406

Effective Date: June 1, 2024 – November 30, 2024

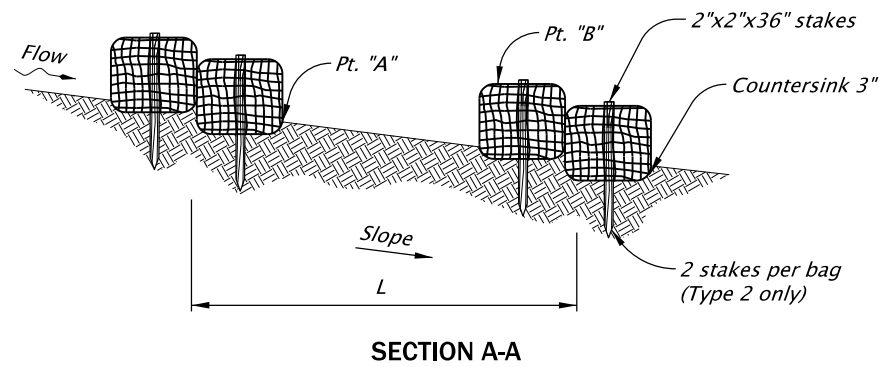
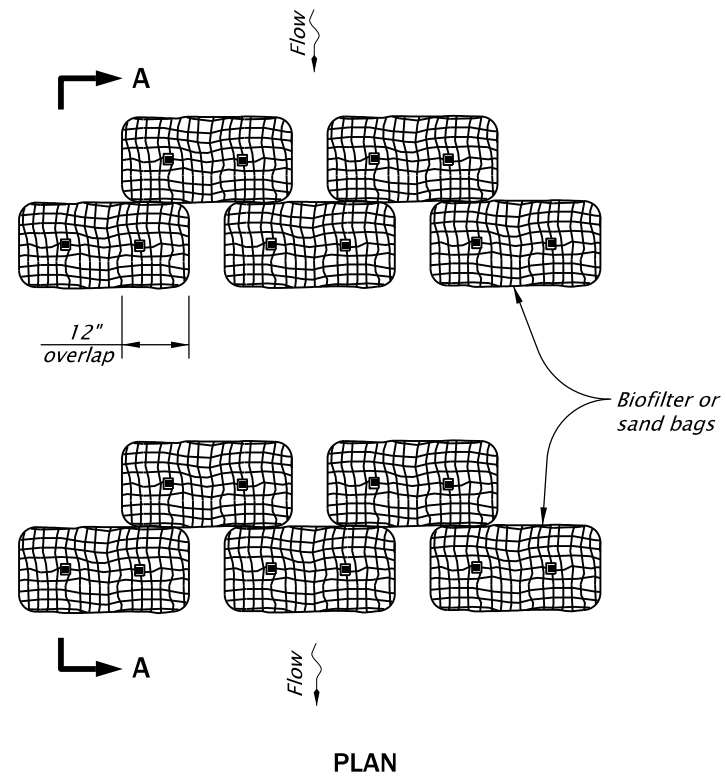

BIOFILTER BAG / SAND BAG BARRIER - TYPE 2 AND 4
NOT TO SCALE

NOTES:

1. For Type 2 barrier, drive stakes flush with top of bag and into undisturbed ground a min. of 12". Omit stakes if bags are placed on paved surface.
2. For Type 2 and Type 4 barriers, space bags (L) so that the elevation of point "A" is less than or equal to the elevation of point "B".

Type 2 - Biofilter bags
Type 3 - Wattles
Type 4 - Sand bags

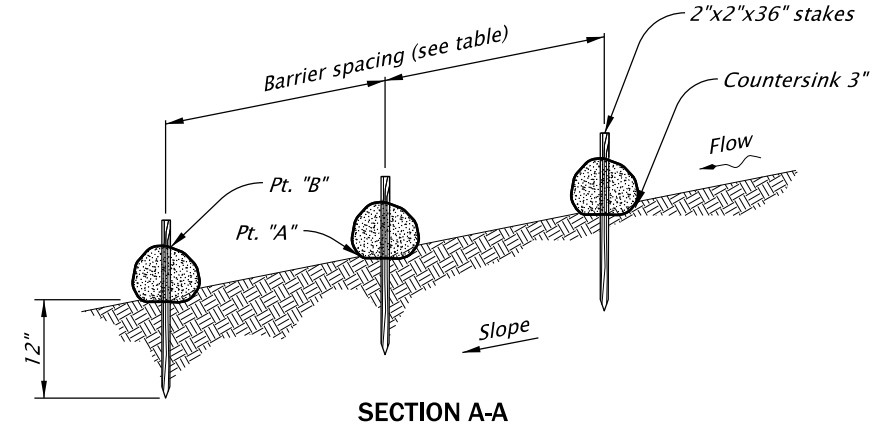
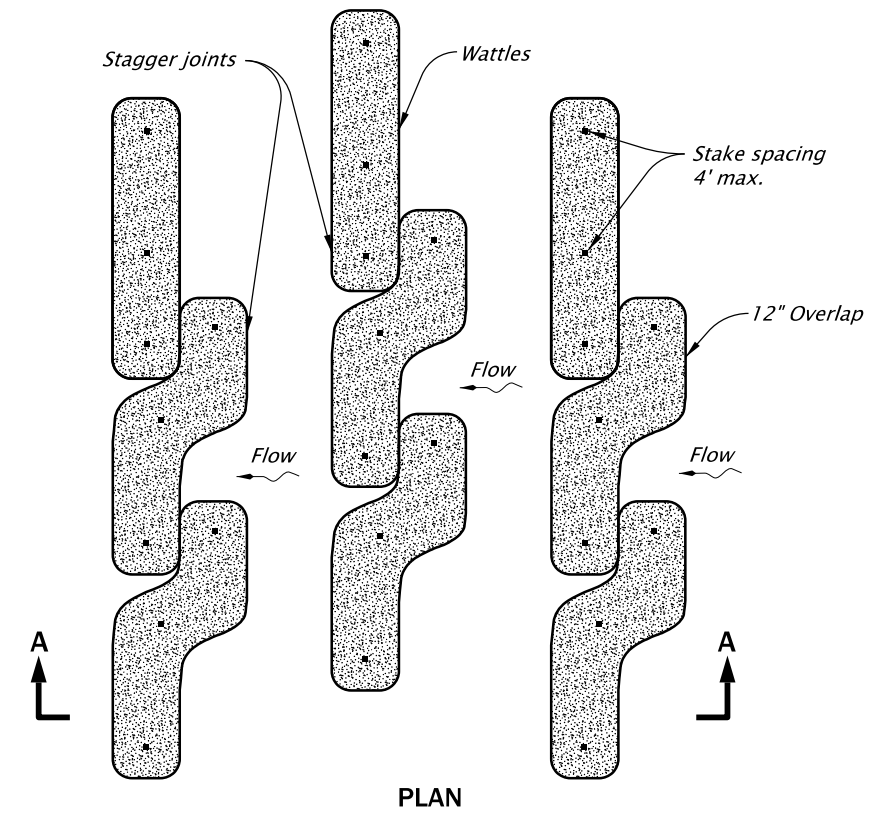

FIBER ROLL BARRIER - TYPE 3
NOT TO SCALE

BARRIER SPACING		
INSTALL PARALLEL ALONG CONTOURS AS FOLLOWS		
% SLOPE	% SLOPE	MAXIMUM SPACING ON SLOPE
10% Flatter	1:10 or Flatter	300'
10 > % ≥ 15	10 > X ≥ 7.5	150'
15 > % ≥ 20	7.5 > X ≥ 5	100'
20 > % ≥ 30	5 > X ≥ 3	50'
Steeper than 30%	Steeper than 1:3	25'

The selection and use of this Standard Drawing, while designed in accordance with generally accepted engineering principles and practices, is the sole responsibility of the user and should not be used without first consulting a Registered Professional Engineer.

All materials shall be in accordance with the current Oregon Standard Specifications.

OREGON STANDARD DRAWINGS

**SEDIMENT BARRIER
TYPE 2, 3 AND 4**

2024

DATE	REVISION	DESCRIPTION
01-2021	REMOVED	CALC BOOK NUMBERS
CALC. BOOK NO.	N/A	SDR DATE: 20-JAN-2021

RD1030